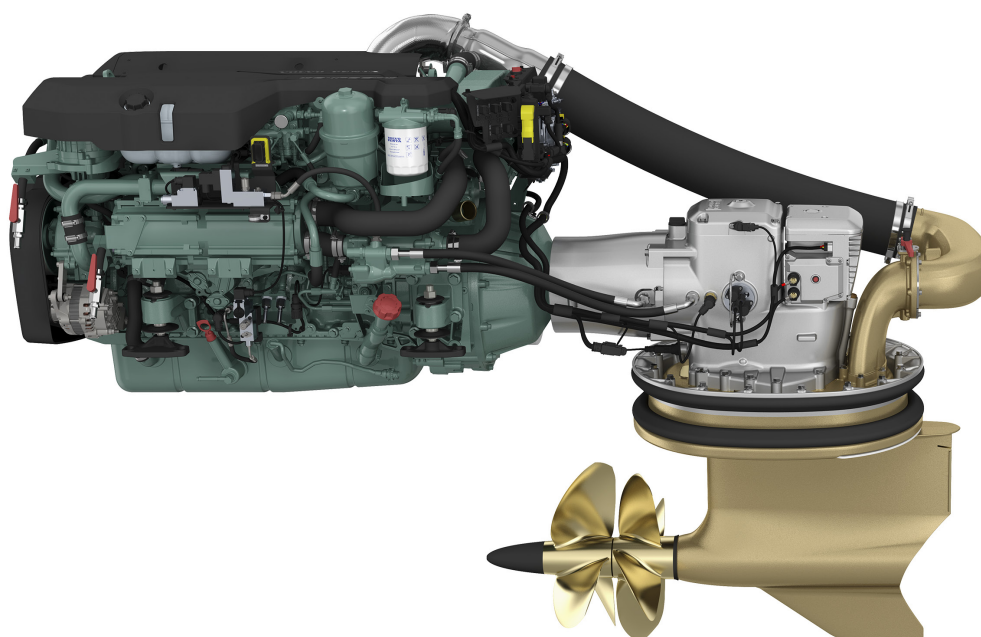

D8-IPS600, -IPS650, -IPS700**NEW!****General**

System designation	D8-IPS600, D8-IPS650 & D8-IPS700		
Engine displacement, l (in ³)	7.7 (469.7)		
Configuration and number of cylinders	In-line 6		
Aspiration	Twin entry turbo and compressor		
Package dry weight, incl. propellers approx. kg (lb)	1410 (3109)		
Propeller series	NS4-NS5, N1-N7		
Voltage	24V		
Emission compliance	IMO NOx, US EPA Tier 3		
Application	Twin and triple installations in planing hulls		
Speed range	20 to 40 knots		

Power & rating

System designation	D8-IPS600	D8-IPS650	D8-IPS700
Rating	3	4	4
Rated RPM	2700	2850	2900
Crankshaft power, kW (hp)	331 (450)	374 (509)	405 (550)
Propshaft power, kW (hp)	321 (437)	364 (495)	392 (533)

Technical data according to ISO 8665. With fuel having an LHV of 42700 kJ/kg and density of 840 g/liter at 15°C (60°F). Merchant fuel may differ from this specification which will influence engine power output and fuel consumption.

D8-IPS600, -IPS650, -IPS700

Technical description:

Engine and block

- Cylinder block made of cast iron
- One-piece cast-iron cylinder head
- Ladder frame fitted to engine block
- Replaceable dry cylinder liners and valve seats/guides
- Drop forged crankshaft with induction hardened bearing surfaces and fillets with seven main bearings
- Four-valve-per-cylinder layout with overhead camshaft.
- Each cylinder features cross-flow inlet and exhaust ducts
- Gallery oil-cooled cast aluminum alloy pistons with three piston rings
- Rear-end transmission

Engine mounting

- Flexible engine mounting

Lubrication system

- Seawater-cooled tubular oil cooler
- Single oil filter of cartridge type, easy to replace without spillage

Fuel system

- Common rail fuel injection system
- Gear-driven fuel pump and injection timing
- Electronically controlled central processing system (EMS – Engine Management System)
- Single fine fuel filter of spin-on type, with water separator and water alarm

Air inlet and exhaust system

- Mid-positioned twin entry turbocharger with aftercooler

- Belt-driven compressor
- Air filter with replaceable inserts
- Wet exhaust elbow (option)
- Loss of sea water alarm

Cooling system

- Seawater-cooled tubular heat exchanger
- Coolant system prepared for hot water outlet
- Easily accessible seawater impeller pump in rear end

Electrical system

- 24V with extra 12V/115A or 24V/80A alternator

Electronic Vessel Control (EVC)

- Fully integrates the engines, electronics and the unique set of EVC features, such as Joystick Docking, Dynamic Positioning System and more

Pod transmission

- Forward-facing, twin counter-rotating propellers
- Electronic steering, enabling features such as joystick maneuvering
- Integrated exhaust system
- Hydraulic gear shift system with low speed mode as standard
- Water in oil sensor
- Oil change from inside the boat
- Nickel Aluminum Bronze and stainless steel in all main under water components
- Complete range of propellers available, covering boat speeds from 20 to 40 knots
- Several optional jackshaft lengths

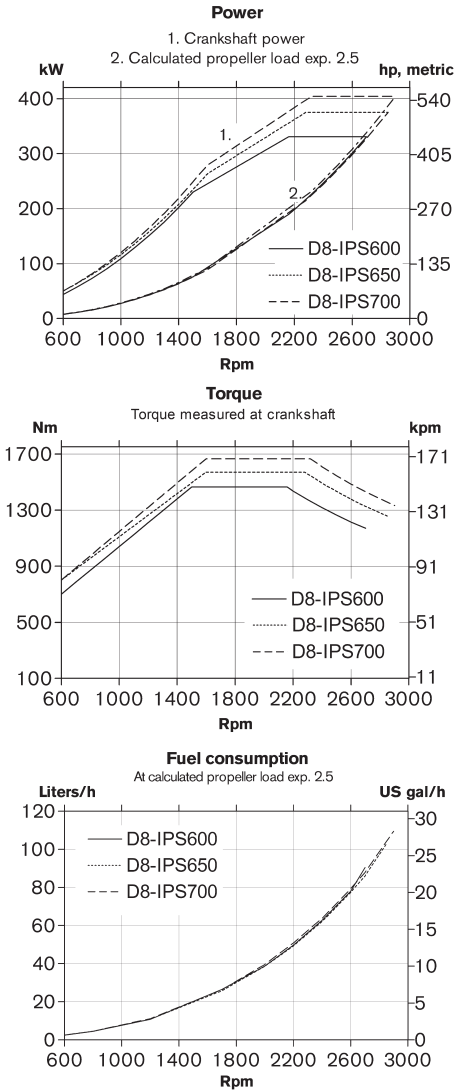

Dimensions D8-IPS600, -IPS650, -IPS700

Not for installation, mm [in.]

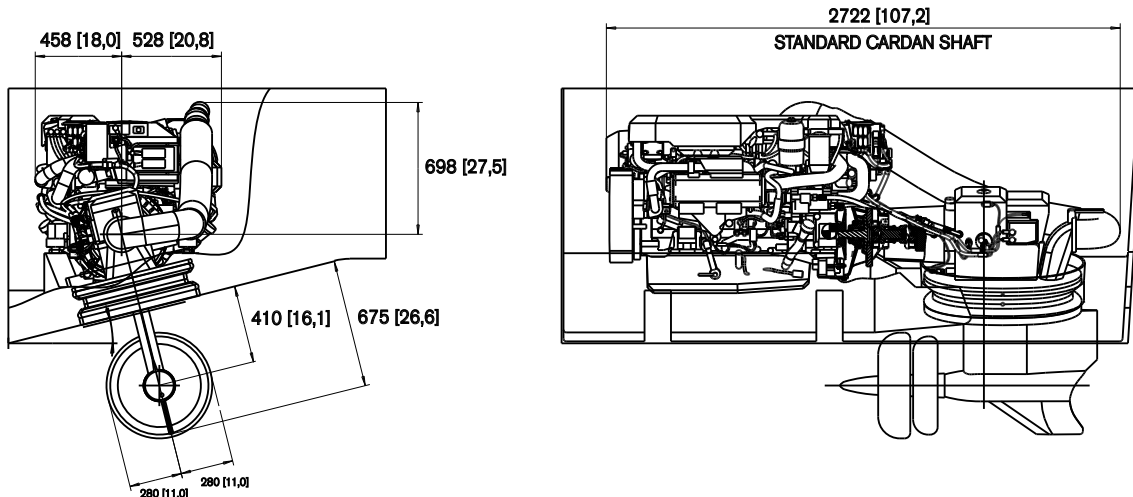

Volvo Penta is part of the Volvo Group, the world's leading manufacturer of trucks, buses, construction equipment and diesel engines. Volvo Penta has approximately 4,000 dealers in some 130 countries.

For further information, please contact your local Volvo Penta dealer or visit www.volvopenta.com.

VOLVO PENTA

AB Volvo Penta

SE-405 08 Göteborg, Sweden
www.volvopenta.com

Not all models, standard equipment and accessories are available in all countries. All specifications are subject to change without notice. The engine illustrated may not be entirely identical to production standard engines.